

# Rice Mixer SUW-M

*Equipped with a proprietary mixing blade for uniform rice mixing*



## Machine Specifications

- Production Capacity : Approx. 1 cycle/minute  
(estimated time from rice loading to discharge)
- Rice Hopper Capacity : Approx. 12kg
- Power Supply : Single-phase AC 100V
- Power Consumption : 120W
- Machine Weight : Approx. 110kg
- Machine Dimensions : 585(width)×736(depth)×1,267(height) mm

\*Machine design and specifications are subject to change without notice.

*Fluffy results thanks to the proprietary technology!*

*Number of parts: 6*

*Suitable for cold rice too!*

※\*30°C or higher

Even cold rice that is difficult to mix can be mixed evenly without crushing the grains, thanks to our unique mixing mechanism and powerful motor.

Equipped with an automatic rice discharge function, and with only 6 parts, it reduces the operator's workload!

# Proprietary technology for fluffy mixed rice

## POINT 1

By using two unique mixing blade to stir the rice, it becomes a fluffy mixed rice dish that incorporates air.



## POINT 2

The cutting-like motion stirs the rice without crushing the grains, improving quality.

## POINT 3

The sheet metal hopper and high-torque motor ensure powerful stirring, resulting in even mixing even with cold rice! \*30°C or higher

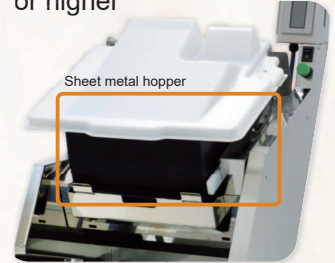

# Not just for mixed rice! High versatility



# Reduces operator workload with automatic rice discharge and easy sanitation

## SANITATION

Easy sanitation with just **6 parts** to clean!

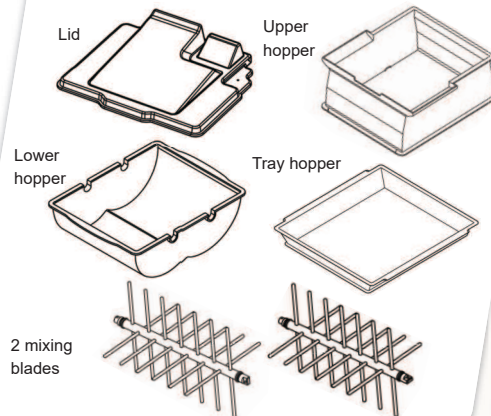

## LABOR SAVING

Equipped with automatic rice discharge

Once mixing is complete, the hopper will rotate automatically to discharge the rice.

Equipped with a steamer tray detection sensor to prevent forgetting to place the container

